

Burford® Entry Level Twist Tyer System

MODEL EL54C

The Burford® Model EL54C Twist Tyer delivers the #1 consumer preferred closure at a lower cost per package for the retail and small wholesale bakery. For optimal performance a minimum bag thickness of 1.25mil is required.

Model EL54C shown with
optional hand bagger



- Proven Burford® twist tyer design
- Most economical closure
- Portable system
- Provides end to end package tightness
- Uses standard ribbon spools

PRACTICAL SOLUTIONS THROUGH INNOVATIVE TECHNOLOGIES

Burford®
bc

CALL US TODAY 1-877-BURFORD (287-3673)

P.O. Box 748 • Maysville, OK 73057 • 1-405-867-4467 • Fax 1-405-867-4219 • e-mail: sales@burford.com • website: www.burford.com

Copyright © Burford Corp. All rights reserved. Burford Corp is a registered trademark with the US Patent & Trademarks office.

ENTRY LEVEL TWIST TYER SYSTEM



The Burford® EL54C is designed to be used with manual or semi-automatic bag loaders to improve the efficiency of the bakery packaging process. With the Entry Level Twist Tyer System, packages are simply placed onto the conveyor and from that point on the feeding and tying process is automated.

Options

- Hand bagger
- Blower Kit

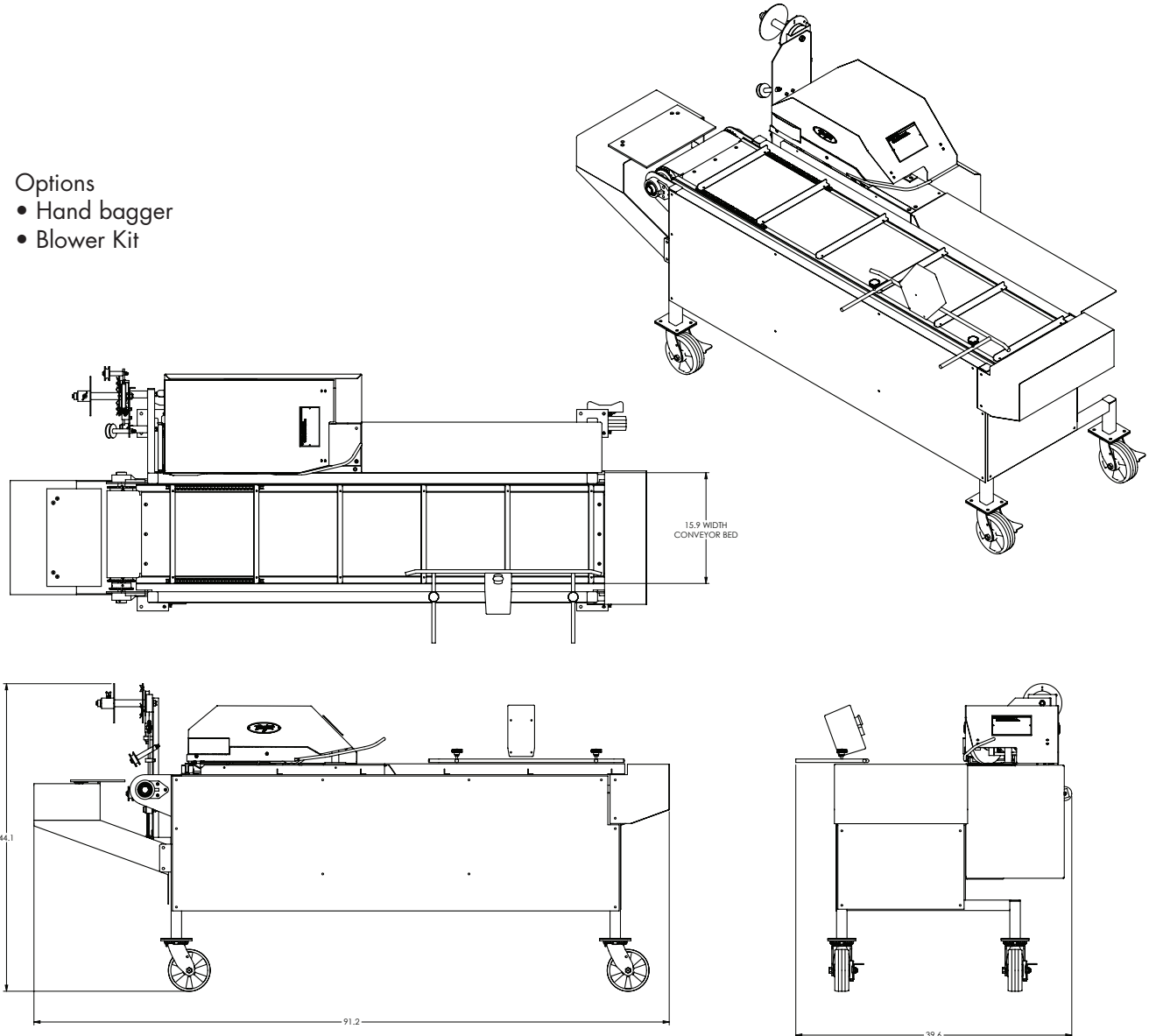

SPECIFICATIONS

ELECTRICAL:

110 VOLT, 50/60 HZ, 1 PHASE, 10 AMPS