

HINDS-BOCK P-50 AUTO-LIFT TRANSFER PUMP



The all new Hinds-Bock model P-50 Auto Lift Transfer Pump is ideal for Bakeries or production plants with limited floor space. It features a very rugged compact design that allows it to come apart in minutes without tools. The Pump is powered in the up position and gravity lowers it down. It can handle a wide variety of products such as bakery batters, fillings and even products with small particulates. A high-low level probe sensor is optional for automatically starting and stopping the pump based on the level in the depositor hopper. Like all Hinds-Bock equipment is designed for multiple shifts a day production.

E-MAIL: info@hinds-bock.com | WEB: www.hinds-bock.com



2122 - 222nd Street S.E. | Bothell, WA 98021 USA
TEL: 877.292.5715 (Toll Free) | TEL: 425.885.1183 | FAX: 425.885.1492

HINDS-BOCK P-50 AUTO-LIFT TRANSFER PUMP

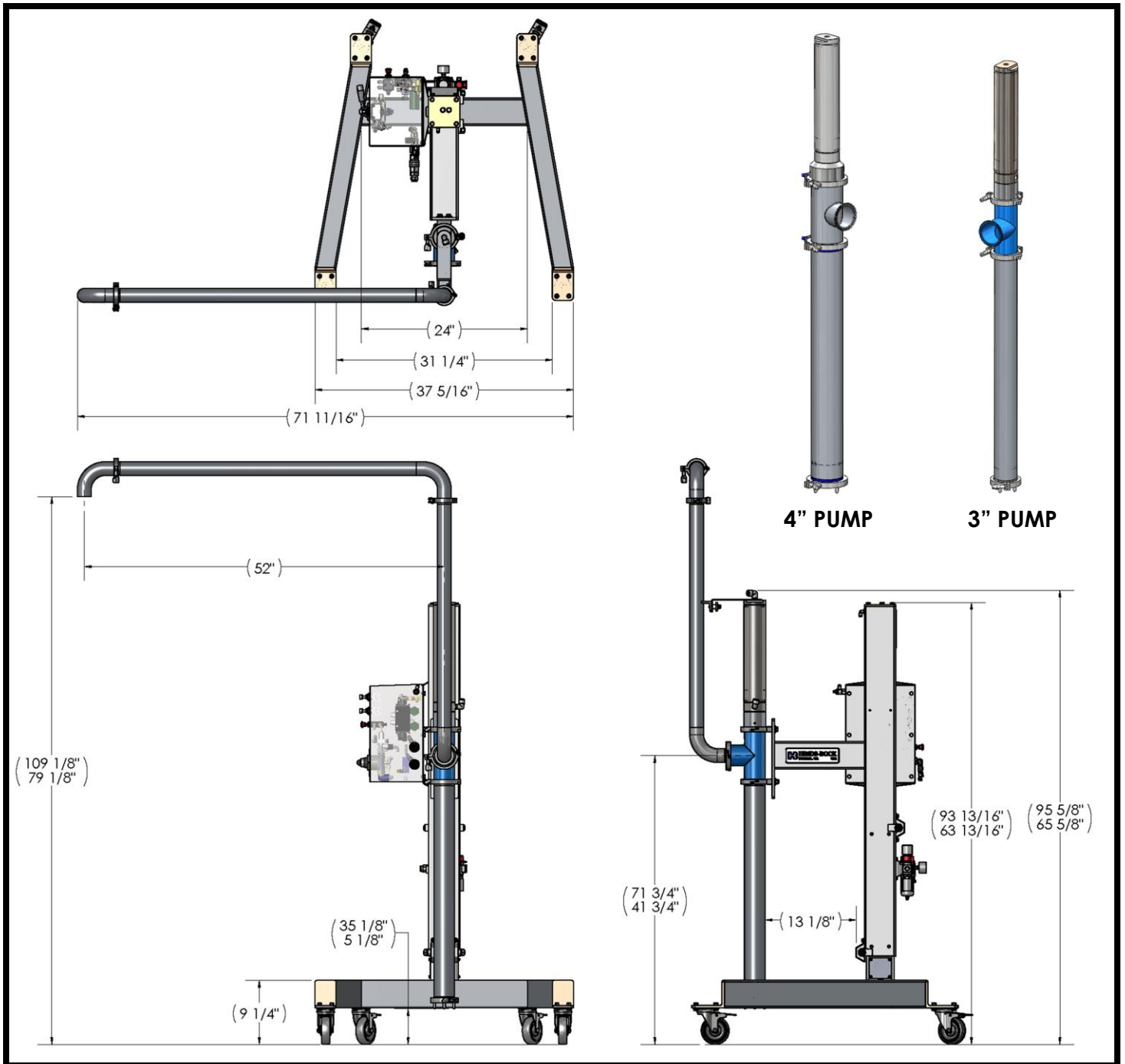

E-MAIL: info@hinds-bock.com | WEB: www.hinds-bock.com

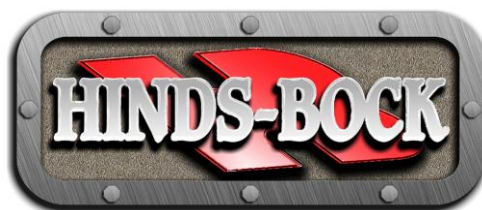

BUILT TO LAST