



LOGIUDICE FORNI
technologies by tradition



Forno rotativo - 10 teglie
Rack oven - 10 trays
Four rotatif - 10 plaques
Horno rotativo - 10 bandejas



ITA FORNO CON CARRELLO ROTATIVO - 10 TEGLIE

Forni consigliati per la cottura di qualsiasi tipo di pane e prodotto per la pasticceria.

- Il forno costruito interamente in acciaio inox.
- Sistema di rotazione con gancio superiore.
- Funzionamento a gas, gasolio ed elettrico.
- Pannello digitale con accensione automatica.
- Doppia vaporiera a cascata.
- Valvola manuale estrazione vapori.
- Porta con doppio vetro e doppio sistema di chiusura.
- Illuminazione camera con due lampade alogene.
- Cappa di aspirazione con aspiratore vapori incluso.

OPTIONAL:

- Pannello digitale 99 programmi con gestione fasi di cottura.
- Supporto porta teglie per 16 teglie.
- Cella di lievitazione o fermalievitazione.
- Carrello.
- Carrello di supporto per estrazione del carrello di cottura.
- Apertura porta reversibile.
- Ruote con freno.

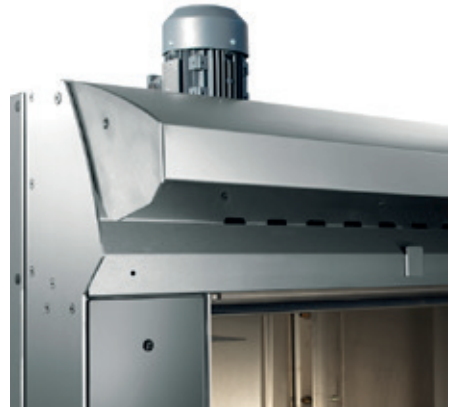

ENG RACK OVEN - 10 TRAYS

Ovens recommended for baking any type of bread or pastry products.

- Heavy duty stainless steel interior and exterior
- Rack rotation system with upper hook.
- Gas, gasoil or electric
- Digital control panel with automatic weekly start up.
- Double built in steam generator, water drop system
- Manual steam exhaust valve
- Double glaze door with double-locking system.
- Double internal light.
- Canopy included.

OPTIONAL:

- Digital control with storage for up-to 99 programmed recipes.
- Oven stand holding 12 trays
- Proofer or retarder proofer
- Rack.
- Rack support for the unloading of the baking rack
- Reversible door opening.
- Trolley wheels with brake.



FRA FOUR ROTATIF - 10 PLAQUES

Fours conseillés pour la cuisson de tout type de pain et de produit pour la pâtisserie.

- Four entièrement en acier inox.
- Système de rotation par crochet supérieur.
- Fonctionnement à gaz, gazoil et électrique.
- Tableau digital avec démarrage automatique.
- Double appareil à buée à cascade.
- Vanne extraction de buée manuelle.
- Porte avec double vitrage et double système de fermeture.
- Eclairage de la chambre effectuée par deux lampes halogènes.
- Hotte de aspiration inclus.

EN OPTION:

- Tableau digital avec 99 programmes et gestion des différentes phases de cuisson.
- Support porte 16 plaques.
- Chambre de pousse ou de pousse contrôlée.
- Chariot.
- Chariot de support extraction chariot de cuisson.
- Ouverture de la porte réversible.
- Roues du chariot avec frein.



ESP HORNO ROTATIVO - 10 BANDEJAS

Hornos recomendados para la cocción de todos los tipos de panes y productos de pastelería.

- Horno completamente en acero inoxidable.
- Sistema de rotación con gancho superior.
- Funcionamiento a gas, gasóleo, eléctrico.
- Panel de control digital con encendido automático.
- Vaporera doble con sistema a cascada.
- Válvula extracción de vapores manual.
- Puerta con doble cristal y sistema de doble bloqueo.
- Iluminación cámara de cocción con dos lámparas halógenas.
- Aspirador de vapores y campana incluidos.

OPCIONAL:

- Panel digital con 99 programas + gestión de la cocción en 9 fases.
- Soporte con capacidad para 16 bandejas.
- Cámara de fermentación calor y humedad.
- Cámara de fermentación controlada.
- Carro bandejero.
- Carro de apoyo para la extracción del carro de cocción.
- Puerta reversible.
- Ruedas con freno.

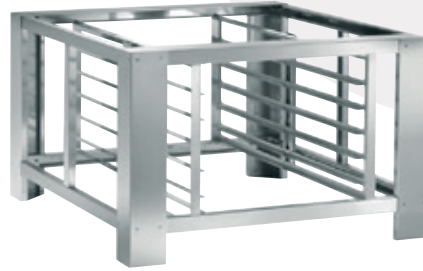

ROTOR FOX

Modello Model Modèle Modelo	Teglie Trays Plaques Bandejas	Dim. teglie Trays dim. Dim. Plaques Dim. Bandejas	Sup. cottura Baking surf. Surf. cuisson Sup. cocción	Spazio teglie Tray Clearance Distance entre plaques Separacion entre Pisos	Dimensioni esterne Outside dimensions Dimensions extérieures Dimensiones externas				Peso Weight Poids Peso
					A cm	B cm	H 1 cm	H 2 cm	
FOX	N°	cm	m²	cm					Kg

10 T

LFRC-10T 40x60	10	40x60	2.4	8.5	100	125	200	220	540
LFRCE-10T 40x60									
LFRC-10T 50x70	10	46x66 45x75 50x70 40x80	3.0	8.5	110	140	200	220	590
			3.4						
			3.5						
LFRCE-10T 50x70			3.2						

Modello Model Modèle Modelo	Potenzialità termica Thermic power Puissance thermique Potencia tèrmica			Ass. elettrico Electric absorption Puissance électrique Potencia eléctrica		
	Kcal/h	Kw	Btu/h	Bruciatore Burner Brûleur Quemador	Resistenze Resistor Résistances Resistencia	
FOX				Kw	*	**
LFRC-10T	20.000	23	80.000	1.5	---	---
LFRCE-10T	---			---	15+1.5	19+1.5

* Pasticceria - Pastry - Pâtisserie - Confiteria

** Pane - Bread - Pain - Pan

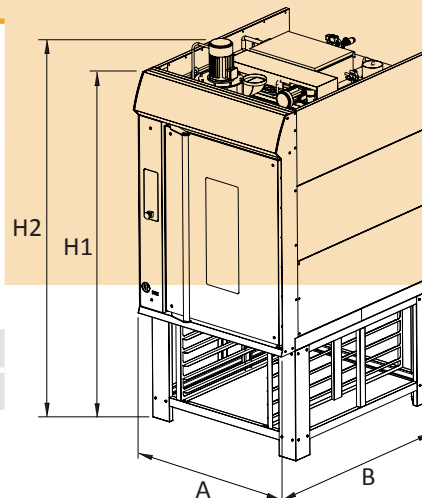

FOX 10T

LFRC



LOGIUDICE FORNI
technologies by tradition

Logiudice Forni srl
Via Madonna Pellegrina, 29
37047 San Bonifacio
Verona - Italy

Tel. +39 045 618 0 126
Fax +39 0442 490 444

logiudiceforni@logiudiceforni.com
info@logiudiceforni.com

www.logiudiceforni.com



FOX 10 T

L'azienda si riserva il diritto di apportare eventuali modifiche nell'ottica di un continuo miglioramento dei propri prodotti.
The Manufacture reserves the right to make any change to the product with the purpose of improving its quality.